

Wiring Diagram

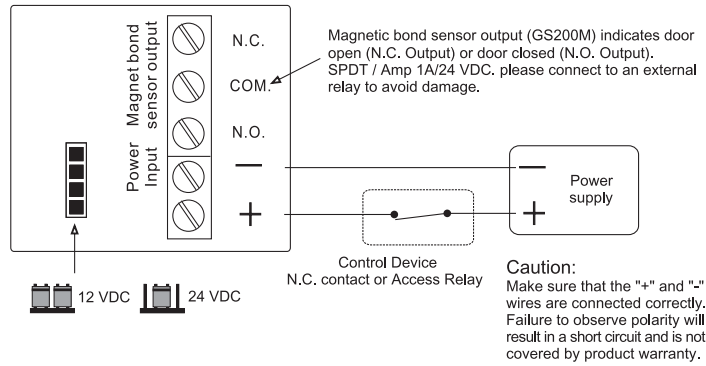

Blind Nut Installation

Drill 9.4mm holes for M6 Blind Nuts. Drill 7mm holes for M5 Blind Nuts.

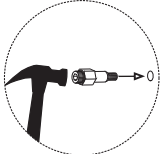

Insert two Blind Nuts into separate holes, one for each fixing screw.

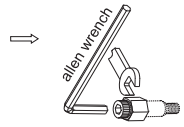

Use the allen wrench to slowly tighten the Blind Nut. (Don't tighten firmly.)

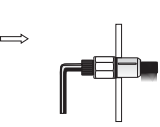

The Blind Nut is tightened so that it remains permanently fixed in the door frame.

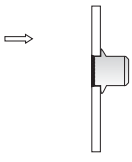

Remove the tool.

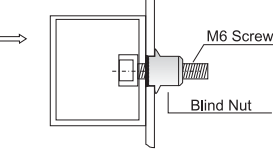

Use M6 Screws to fix SMB-001 brackets.

For Vertical Installation

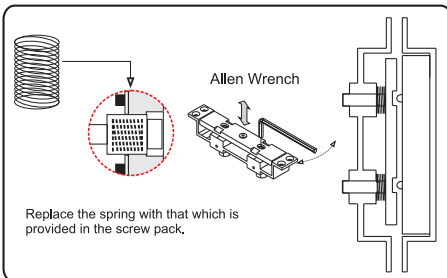

Replace the spring with that which is provided in the screw pack.

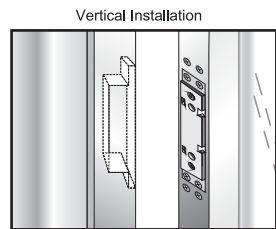

Vertical Installation

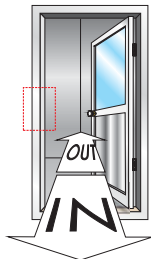

GS200 Mini Shear Lock Installation Instruction

Specifications

| | |
|-----------------------|-------------------------------------------------------------------|
| Shear Holding Force | Up to 1200 lbs (545Kg) |
| Operating Voltage | 12/24 VDC |
| Current Draw | 420mA/12 VDC; 210mA/24 VDC |
| Finish | Magnet and Armature: Zinc plated |
| Monitor Output | Magnetic bond sensor output SPDT rating 0.5A/125VAC; 1A/24 VDC |
| Door Gap | 2mm |
| Operating Temperature | -30°C to +50°C |

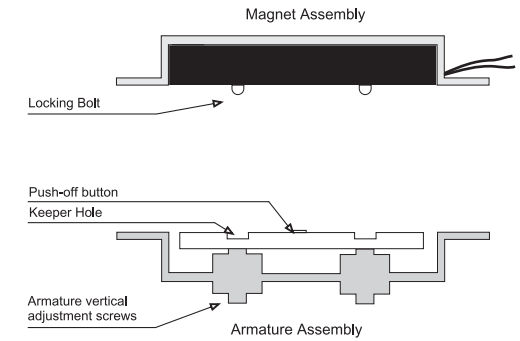

Dimensions

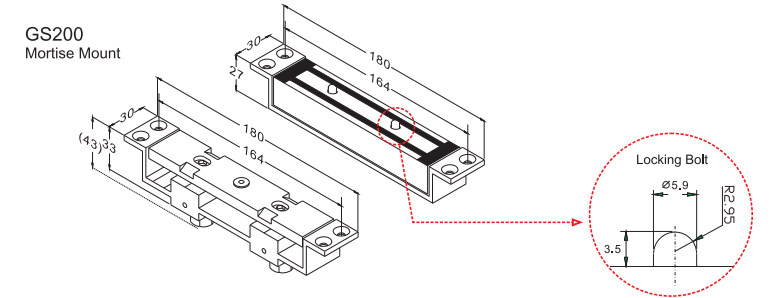

Unit: mm

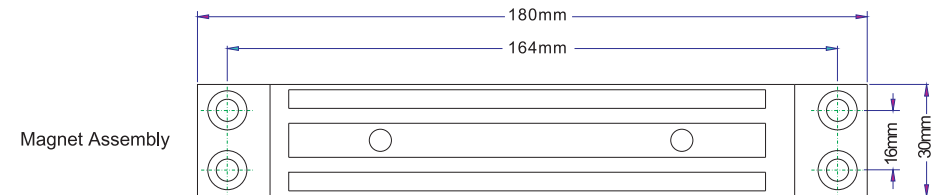

Magnet Assembly

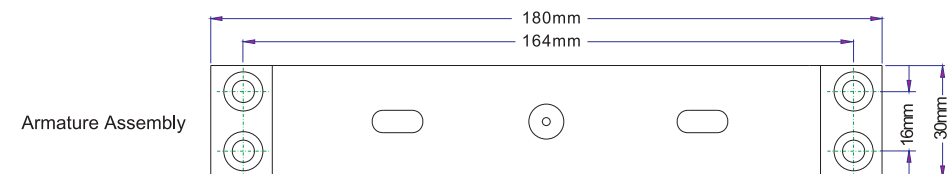

Armature Assembly

Important Notes

Make sure that the door and frame is wide and deep enough to install the shear lock. Make sure the central lines on the door frame and door leaf align. Install the magnet into the door frame before installing the armature assembly into the door leaf.

Before installation, make sure the door always returns to the dead center after it is opened, especially double-action doors. Use door hinges if necessary.

Mortise Mount

1. Make sure the gap between the door top rail and frame header is 2 mm.
2. Mark the central lines on the door and frame where the magnet and armature assembly will be installed.
3. Attach the templates to the door and frame.
4. Cut and drill holes where the templates indicate. Connect the wires. Install the shear lock and armature assembly towards the leading edge of the door.
5. Connect to the power and check the unit.

A. For proper operation, the armature assembly must be close and parallel to the shear lock, without interfering with opening and closing of the door. Keep a distance of 2 mm between the armature assembly and the magnet.

B. If the magnet attracts the armature assembly when the door is not in position, please adjust the door operator and floor hinges.

C. If there is no bond sensor output, please remove secondary diode installed across the magnet. Also adjust the surfaces of the shear lock and the armature assembly.

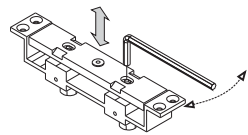
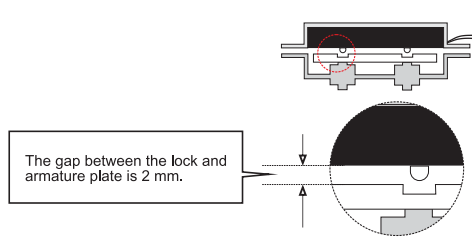
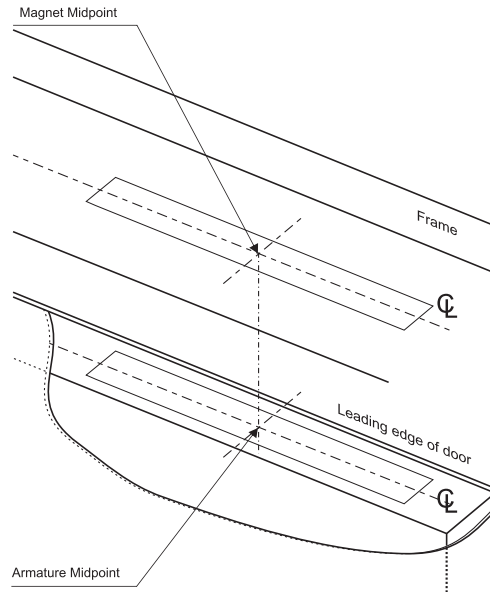

Proper operation cannot be expected with more than 2 mm gap between the armature and the magnet. Use the allen wrench provided to adjust the screws of the armature.

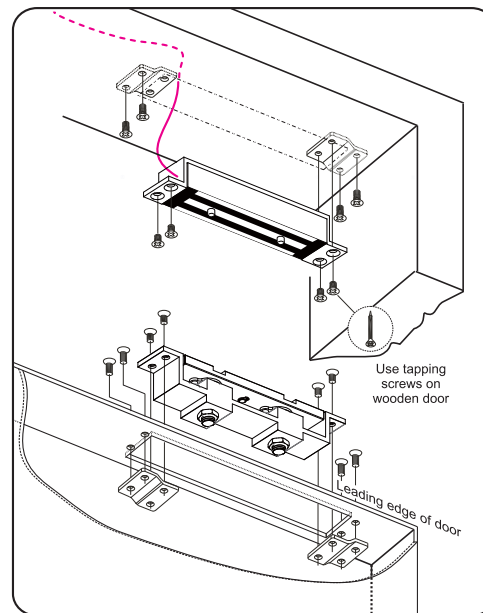

Optional Bracket

The unit may also be semi-surface or surface installed with the use of the SMB-200, UBK-182 and SMB-250 Brackets. The magnet should be fitted to the door transom and the armature on to the door. It is vital that a maximum gap of 2 mm exists between the magnet and the armature, to allow for correct operation.

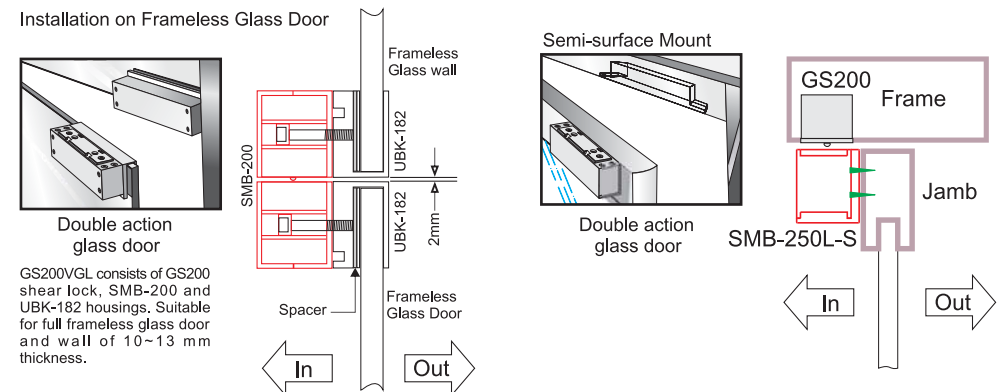
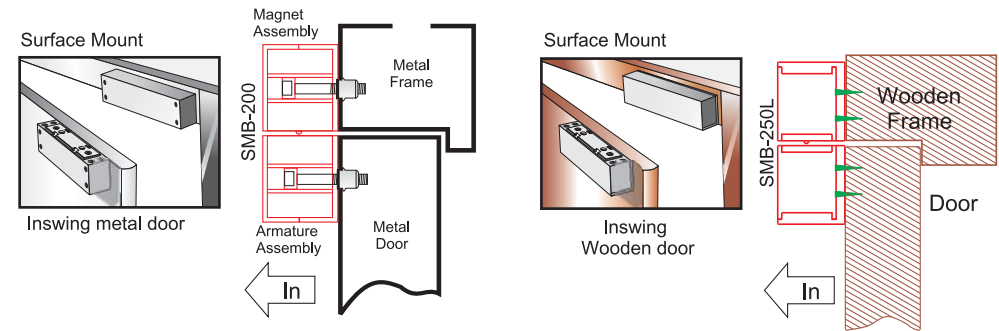
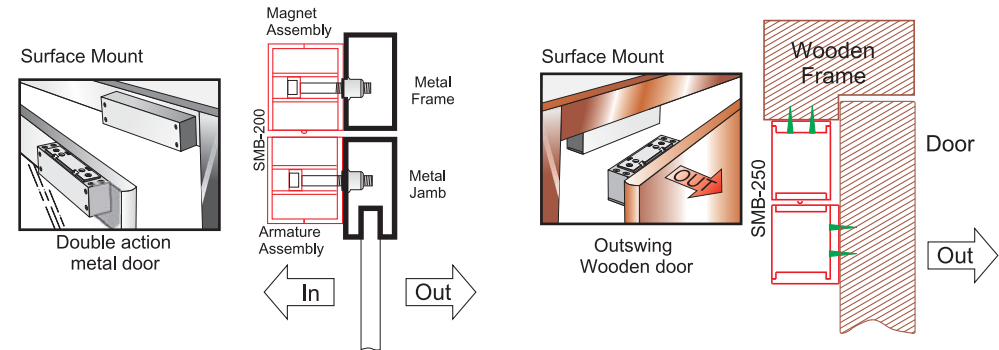
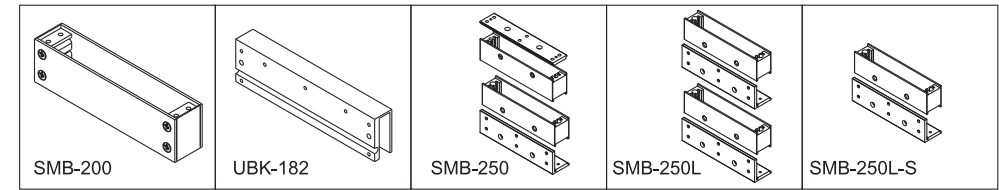

GS200VGL consists of GS200 shear lock, SMB-200 and UBK-182 housings. Suitable for full frameless glass door and wall of 10-13 mm thickness.